

UNIT : mm

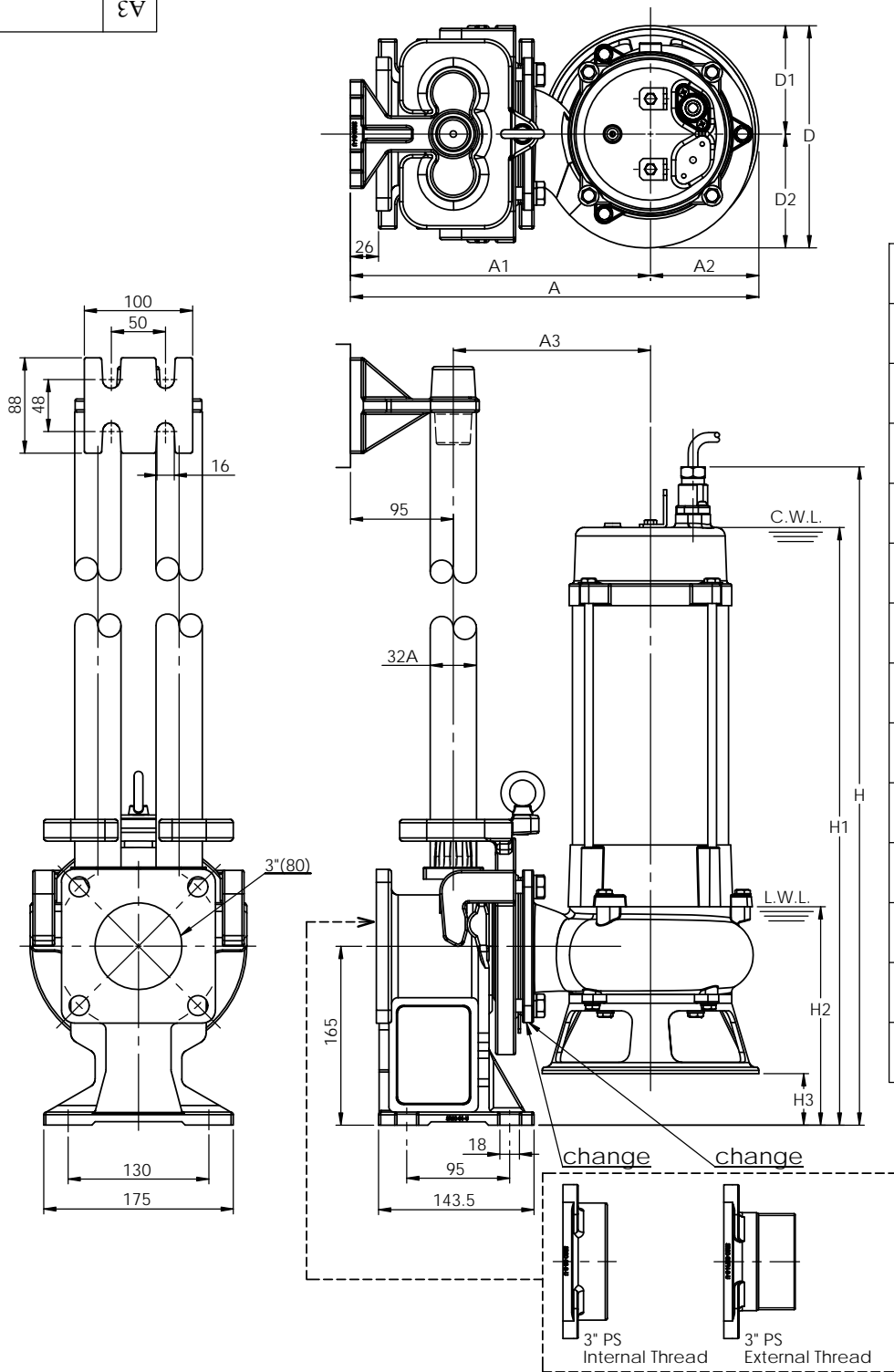

NO.	TYPE	A	A1	A2	A3	D	D1	D2	H	H1	H2	H3
1	JS1500S	381	281	100	186	206	100	106	616	560	210	55
2	JST15S	381	281	100	186	206	100	106	548	492	210	55
3	JST22S	404	300	104	205	214	103	111	629	532	211	55
4	JST37S	417	297	120	202	240	120	120	651	554	218	41
5	JS1500SK	381	281	100	186	206	100	106	616	560	210	55
6	JST15SK	381	281	100	186	206	100	106	548	492	210	55
7	JST22SK	404	300	104	205	214	103	111	629	532	211	55
8	JST37SK	417	297	120	202	240	120	120	651	554	218	41
9	JST8SV	363	269	94	174	170	85	85	516	460	218	78
10	JS1500SV	375	279	96	184	190	91	99	635	579	243	48
11	JST15SV	375	279	96	184	190	91	99	567	511	243	48
12	JST22SV	416	312	104	217	206	103	103	643	546	240	60
13	JST37SV	450	317	133	222	252	119	133	695	598	253	15

UNSPECIFIED TOLERANCES: ANGULAR: $\pm 0^\circ 30'$ LINEAR: PLASTIC MOULDING: ± 0.3 OTHERWISE: REFER TO LINKED FILE	DATE: 2016-11-28	久欣電機股份有限公司 JOUNG SHIN ELECTRIC CORP.	THIRD ANGLE PROJECTION	
	DRAWN: LU		MATERIAL:	
	CHECKED: HUANG	TITLE: SR80-U雙軌著脫與幫浦安裝尺寸圖 SR80-U Double-rail slide rail pump installation dimensional drawing.	A3	A
	SCALE: 1 : 4.5			